



Humidity Group

of the *HEVAC* Association

Code of Best Practice 4

Commissioning and Planned Maintenance



HEVAC Association

Humidity Group

This code has been structured to include deliberate duplication between some sections, so that the relevant section for a customer's specific system can be removed and followed.

The code has been drafted by specialists in each product category. However, it is acknowledged that not all products may be included and some manufacturers may observe variations to the generic norms presented.

CONTENTS

	<u>Page</u>
1. Introduction	1
2. Safety, and Compliance	2
3. Commissioning	4
4. Routine Maintenance	
4.1 Isothermal	5
4.1.1 Electrode boiler	6
4.1.2 Resistive element	8
4.1.3 Direct steam	10
4.1.4 Gas fired	13
4.2 Adiabatic	16
4.2.1 High pressure water	17
4.2.2 Compressed air/water	20
4.2.3 Ultrasonic	23
4.2.4 Wetted media	25
4.2.5 Spinning Disk	27
4.3 Mobile/portable	30
5. Ancillary Services	
5.1 Water supply and treatment	31
5.2 Controls and calibration	33
6. Conclusion	37

SECTION 1 - INTRODUCTION

1. Introduction

This guide provides information and advice on good practice in the commissioning and maintaining of a wide range of different types of humidifier. It is intended for anyone who has an interest in running humidifiers efficiently, effectively and safely, such as maintenance organisations, service personnel, facilities managers, end users and building services consultants. As such, it is orientated towards planned, preventative maintenance rather than taking a reactive break/fix approach.

Humidifiers represent one of the most complex aspects of any indoor environmental control system. Although there are just two primary principles involved, isothermal steam and adiabatic cold water systems, the range of different types of humidifier is wide. Steam humidifiers include resistive, electrode-boiler, direct steam, indirect hot water- or steam-to-steam humidifiers, and gas-fired units. Adiabatic cold water systems comprise evaporative wetted media units, high pressure sprays, compressed air sprays, rotary atomisers and ultrasonic humidifiers. In addition, there is a wide range of steam and adiabatic mobile or portable humidifiers in use.

Irrespective to the type of humidifier employed, they will always involve a water supply, a single and/or three phase electrical power supplies and a control system of some sort. According to the type of humidifier, there might also be a water treatment system such as reverse osmosis or UV sterilisation, gas supply, compressed air, steam distribution network, sprays and drainage. A diversity of skills can therefore be required in addition to which are Health & Safety considerations such as working at height, lone working, high and low temperatures, chemicals and possible microbial contamination such as Legionella bacteria.

Furthermore, the wide diversity of water quality, the application itself (an industrial process application is very different from an office environment or food display counter, for example), the criticality of the application, the heaviness of use and the seasonality of many humidifier applications mean that maintenance needs vary considerably from one situation to another. Failure to commission correctly, and to plan and carry out maintenance properly, can lead to failure of the humidification system to perform as designed, lost productivity and quality, discomfort for building occupants, strained customer relations, wasted energy, unnecessary running costs and unsafe operation.

The variety of humidifiers and the multiplicity of factors affecting their performance means that many of those who carry out commissioning and maintenance may not have sufficient understanding or skills to ensure their proper operation.

This guide aims to provide basic information and advice on commissioning and maintenance of a wide range of humidifiers. However, it is not a substitute for manufacturers' Operation and Maintenance manuals, which should always be read before commissioning and when planning or carrying out maintenance. It is also no substitute for ensuring that staff responsible for commissioning and maintenance understand the requirements of the equipment they are maintaining and are properly trained to do the work concerned. Whilst there is currently no recognised standard or qualification for a specialist humidification engineer, the Humidity Group recommends that it should be someone either from the relevant humidifier manufacturer or supplier, who typically carry a dark green Construction Related Services Humidification Skillcard (or their approved nominated contractor), or a person trained by the supplier or manufacturer of the humidification equipment concerned.

Most humidifier manufacturers and suppliers offer suitable training, and provide commissioning and planned maintenance services, to help ensure that customers get the best from their equipment and the peace of mind that comes with knowing that their investment is being maintained by appropriately trained people. If in doubt, do not hesitate to seek the advice or services of the manufacturer or supplier.

SECTION 2 – SAFETY AND COMPLIANCE

2.1 Health and Safety Overview

Humidifier commissioning, maintenance, repair work and decommissioning should only be carried out by properly trained and suitably qualified personnel, and in accordance with the manufacturer's instructions. It is the responsibility of the organisation responsible for maintenance of the humidifier to ensure the suitability of the staff concerned, and that full information on the system concerned is available to them.

Any potential Health and Safety hazards should be identified in advance of work being carried out by a suitably skilled and competent person, and suitable control measures put in place to minimise risks to persons and property. The use of Personal Protective Equipment (PPE) should always be determined in relation to assessed risk.

Commissioning and maintenance should always be carried out in accordance with local legislation and byelaws such as those relating to connection to the mains water supply, power supplies, the Control of Substances Hazardous to Health (COSHH) regulations, gas regulations, pressure directive and regulations relating to the control of Legionnaires' disease (see 2.2 below). Certain applications, such as those affecting the food industry, are also subject to particular legislative requirements.

Always isolate services such as compressed air, electricity, gas and water supplies before commencing any maintenance. In situations where the services must be running during commissioning or maintenance, particular attention is required to ensure that any Health & Safety risk is identified and controlled.

Modification of any humidifier and failure to use service items or spare parts supplied by the humidifier manufacturer or supplier may invalidate the manufacturer's warranty, leave the humidifier in an unsound or unsafe condition, and reduce its operating effectiveness.

2.2 Legionnaires' Disease

Legislation and guidance regarding the prevention of risks associated with Legionnaires' disease varies from country to country. In the UK, this is governed by the Health and Safety at Work Act, COSHH regulations and, particularly, the Health and Safety Executive's (HSE) Approved Code of Practice and Guidance (ACoP) L8, Legionnaires' Disease: The Control of Legionella Bacteria in Water Systems.

If poorly designed or inadequately maintained, water systems can support the growth of microorganisms including the bacteria that cause Legionnaires' disease, a form of pneumonia which can be fatal. Legionella bacteria are particularly prone to develop in situations where the water temperature is between 20-45°C, where water can stagnate (such as deadlegs and storage tanks) and where there is a ready source of nutrition for the microbe. The bacterium enters the respiratory system of individuals through inhalation of water droplets (such as sprays, aerosols, showers and splashes) which contain the microbe.

Under ACoP L8, it is the responsibility of the employer or person in control of a building to ensure that a suitable and sufficient assessment is carried out to identify and assess the risk of exposure to Legionella bacteria from the water system and work activities in the building, and to carry out any necessary precautionary measures. This person on whom this statutory duty falls also has a responsibility to ensure that this is carried out only by suitably competent persons. Where the assessment indicates potential sources of risk, a programme designed to either prevent or to monitor and control exposure to Legionella must be implemented. This risk assessment should be regularly reviewed and records kept of the monitoring, control and review procedures.

Humidifiers that are plumbed into a water supply form an intrinsic part of a building's water system and must be included in the monitoring and control regimes required by ACoP L8. Mobile humidifiers that are filled with water manually can also harbour such bacteria, particularly if left standing with reservoirs containing water in a warm environment, and must similarly be considered for risk.

With respect to Legionella risk, steam humidifiers generally represent a lower risk than cold water systems. The HSE's ACoP L8 instructs that humidifiers which generate an aerosol must be tested for Legionella every six months. In certain applications, such as food retailers, manufacturers recommended the same water is also tested for listeria, TVC, E.Coli and other coliform bacteria. The maximum recommended period between cleaning and disinfection should be no less than six months but this should be subject to competent risk assessment in relation to the water system as a whole, the application itself and the results of subsequent water testing for the application concerned. Where the humidification system does not incorporate design features such as automated drain down, automatic pipework purges, absence of dead legs, antimicrobial water treatment or where there is elevated water temperature or ambient temperatures exceed 20°C, the risk of Legionella contamination might be greater and this should be reflected in the risk assessment, with more frequent monitoring and control required.

In the UK, manufacturers and suppliers have a responsibility to minimise the risk of Legionnaires' disease in the design of their equipment and through guidance in their Operation and Maintenance manuals. In assessing risk and planning a monitoring and control regime for a humidifier, it is essential to read the O&M manual thoroughly to understand the risk reduction design features of the humidifier, their operation and required maintenance. For example, a humidifier which presents a minimal risk whilst in frequent use might present a significant hazard if turned off for a prolonged period. Turning off the power supply might disable an autodrain feature, leaving it filled with water which would stagnate. Putting it back into operation without due precautions might then disperse contaminated water.

Humidifier operation is typically seasonal and maintenance requirements vary according to the time of year. During extended periods when humidifiers are out of use, they might require decommissioning to ensure that water does not stagnate within pipework, and chlorination and re-commissioning prior to the humidification season.

Consult ACoP L8 and the humidifier manufacturer's Operation and Maintenance manuals for further information and guidance.

2.3 Responsibility and audit trail

When maintenance is carried out, a record should be kept with details of humidifier hours run, work carried out, parts replaced, how long the job took and who did the work concerned. This not only gives assurance that routine and necessary work has been done appropriately but, in the event of problems or dispute, provides an audit trail and traceability. It also provides information for other service technicians for the benefit of continuity, fulfils quality management requirements, helps establish the frequency of future maintenance interventions and provides cost data for overhead evaluation. Where service work is subcontracted to a third party, such as a humidification maintenance specialist, a report of work done should always be a requirement.

In relation to Legionella control, a record of monitoring and control work is a legal requirement. This should include details of whom the statutory duty holder is, the risk assessment of the systems concerned, whom the persons responsible for maintenance are, water sampling frequency, tests and results, routine maintenance, cleaning and disinfection dates and details. Only competent persons, as defined in L8, should be used to repair, maintain, clean and disinfect humidification systems. Full details of these requirements can be found in the HSE's ACoP L8.

Where maintenance is covered by a third party, who might be contracted by the end user or subcontracted by a facilities management company, it is important to set up a planned maintenance agreement which clearly establishes the respective responsibilities of the parties concerned. It is commonly the case that major service work is contracted to a third party specialist with interim maintenance work carried out by the end user or the FM company.

This is particularly relevant for any works carried out on a sub-contract basis with respect to Legionella monitoring and control, given the responsibilities in law concerned. Whilst some humidifier specialists will take on responsibility for this work, others will limit their responsibilities to the mechanical and electrical aspects of maintenance. Whilst this might include hygiene-related work, such as disinfection of cold water systems, it is ultimately the responsibility of the person upon whom the statutory responsibility falls to ensure that this work is carried out effectively, and clear division of responsibility is essential to management of this.

SECTION 3 - COMMISSIONING

3. Commissioning

3.1 Introduction

The commissioning phase of the installation of any humidification system will improve the system performance, energy efficiency and safety. The design specification is essential for commissioning providers to understand, as the design of the systems are often the root cause of problems identified during testing and commissioning.

Humidification systems can be complex, expensive to operate, and high maintenance. It is therefore fair to say that humidification systems are rarely employed unless they are essential, however humidification systems can yield substantial cost and health benefits to any end-user. Humidification systems can be an energy intensive process that can also create moisture problems if not correctly designed, installed and serviced throughout its working life. It is imperative therefore that the commissioning aspect of any humidification systems is carried out prior to hand-over to ensure its life long success and operation.

3.2 Commissioning

Commissioning of more complex and specialist humidifier installations is commonly contracted out to the manufacturer or supplier. However, it is not uncommon to arrive at site to find the installation incomplete, necessitating a return to site with attendant costs. To establish readiness and responsibility, most suppliers or maintenance companies will send pre-commissioning checklists in which the client is requested to confirm that installation is complete, all services available and control signals are in place, and that the equipment is accessible.

In situations where there is a dispute over performance, this is commonly resolved by working closely with the controls company, so it is useful to have a competent representative from the controls company available at the time of commissioning.

Because of the need to have several services in place, humidifier commissioning is often left to the last minute before building handover. It is rarely simply a matter of turning the unit on. Often the equipment is incorrectly installed and even basic services like water, control signal and drain incomplete or unavailable. Plenty of time in advance of project handover should be left for commissioning.

A reputable commissioning company will provide a full commissioning report, covering matters such as installation and any deviation from recommended install procedures, snags that might impact on performance in the future, the humidifier's operation in relation to the controls and effectiveness, any limitations to running the unit under full operational conditions, and any potential matters of hygiene.

3.3 Maintenance

It is important to plan maintenance in accordance to the manufacturer's recommendations and tailor that to the requirements of the application concerned and in relation to water quality. When a preventative planned maintenance schedule is devised, it is good practice to monitor performance regularly at the outset and establish the particular requirements for the site. Where seasonality is influential, it can take a year of running and maintaining a humidifier before a specific pattern of intervention is completely understood for a particular site.

Many humidifiers require regular replacement of major components, such as the boilers/cylinders in electrode-boiler humidifiers. A humidification specialist will typically bring required spares and service items to site for maintenance work but it is good practice for the customer to hold a stock of service items and commonly used spare parts. This can save time and reduce costs as orders for maintenance work do not always cover required parts, for which authorisation might be required. Recommended spares lists are available from your humidifier supplier.

SECTION 4 – ROUTINE MAINTENANCE

4.1 Isothermal

All humidifiers use water. Electrode, Resistive and Gas-Fired types convert that water in to clean steam that does not carry over solids in to the air stream but does leave behind a scale formation and the accumulation of solids in their cylinders, and so requires regular maintenance to ensure their consistent and safe performance. Failure to maintain them can result in reduced output, higher energy costs, shortened humidifier life and poor control of humidity levels.

Manufacturers' operations and maintenance (O&M) manuals provide guidance on performance checks, maintenance schedules, cleaning and de-scaling requirements.

The frequency and type of maintenance must take into account the safe working life of the system's components such as electrodes, cylinders, pumps, valves and electrical components. Even though a schedule of maintenance might be proposed by the manufacturer in their O&M manual, a review by the end user should be undertaken, based on a risk assessment of the system and significance of humidification in that application.

Many humidifiers require regular replacement of major components, such as the boilers/cylinders in electrode-boiler humidifiers. Reputable suppliers maintain a stock of such service spares as a matter of course, but it is advisable to maintain a stock of regularly used items on site.

4.1.1 Electrode Boiler Humidifiers

Overview

The compact nature of the electrode boiler and its ability to produce steam rapidly make it a common choice for air conditioning OEM's in their close control ranges. The Electrode Boiler has a relatively low capital cost and is easy to install, which makes its use widespread throughout most types of application requiring humidity. An isothermal system doesn't affect the temperature of the surrounding area and together with its hygienic nature allows it to be used within both hot and cold food cabinets. Again on the subject of hygiene, only systems utilising steam are permitted in hospitals and you will also find many such systems employed in animal welfare. It is common to use local steam generation within the leisure industry in saunas and for the more obvious steam room.

Principle of operation

Electrode boilers rely on the conductivity of the minerals within the water to pass an electric current between electrodes and the resulting resistance thereby boils the water. Resistance will vary according to the water quality and the cylinder selected for the water on site.

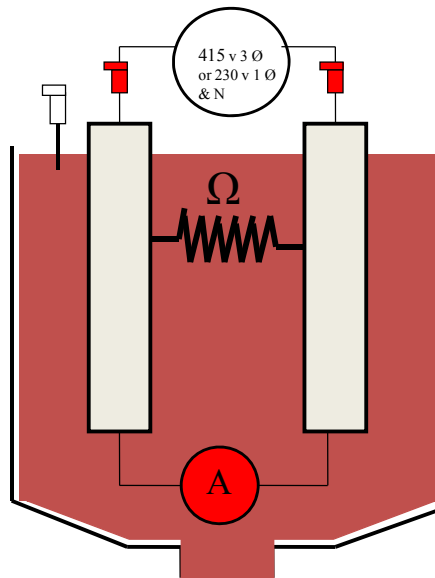

Electrode boiler principles

Water supply

Typical operating range would be:

Hardness	50 to 500ppm
Conductivity	80 to 1000 micro Siemens/cm.
Silica	0

As a rule an electrode boiler should be fed with raw mains water rather than softened or treated and to maintain its optimum output will need to drain and refill from time to time. It is therefore of paramount importance that components associated with the fill and drain, such as the pump, valves and strainers are regularly inspected and maintained.

Routine inspection and maintenance

The cylinder or electrodes are sacrificial items depending on the manufacturer, and will need to be replaced at some stage; the effective life of that cylinder will be determined by the water quality and the humidity demand on site. However, as a guide the cylinder or electrode may need to be changed as often as once a month in the event of high demand, in other cases as little as once a year, the average is probably about three, per annum. Cylinder life can be extended by regular cleaning and to facilitate this many manufacturers offer a cleanable or splittable version. The materials they are made from are the same as that of the standard, and so will degenerate at the same rate if not regularly maintained. To gain an advantage and extend the operational life of the cylinder an inspection and cleaning procedure would need to take place on a monthly basis. The procedure for changing a cylinder can be found in the manufacturer's manual, but also if the cylinder is to be re-used check that the electrodes have not rotated within the cylinder and check that the seal or "O" ring is still in place.

Boiling water containing 500 ppm of temporary hardness particles would precipitate 0.5 g for every kilogram of steam that is produced! Most of this will be expelled with the drain water but some will be retained within the boiler, necessitating regular maintenance.

Hygiene

Electrode Boilers, when boiling water to produce steam, will kill all known bacteria and introduce sterile moisture from the outlet point of the humidification system. This assumes all components within that system are applied in accordance to the guides and recommendations (published and freely available) from the manufacturer. When operational the temperature of all components in the steam path will exceed 60°C therefore sterilising those components as steam is passed through. At full output steam will be at 100°C, exceeding the limits set by ACOP L8.

4.1.2 Resistive Element Humidifiers

Overview

The resistive heater type, being isothermal can be utilised in most of the same applications as the electrode boiler, but its tolerance to water quality may make it the preferred choice in some areas.

Principle of operation

The method of boiling water is by use of resistive heating elements, in essence, as those employed in the common kettle.

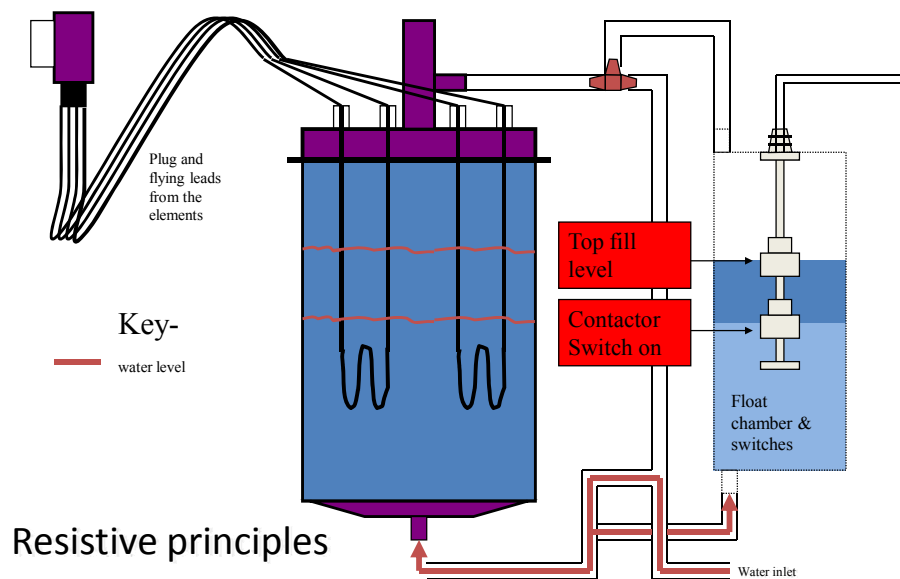

Water supply

Typical operating range would be:

Conductivity	0 to 1000 micro siemens/cm
PH	7.3 to 8.00
Silica	0
Chlorine	170 ppm

There have been instances of chlorine being present in small quantities in the supply water. As the water is boiled the concentration of chlorine builds until it starts to attack the stainless steel elements or cylinder. Tests have shown that normal drain intervals would take care of the build up of concentration assuming the initial chlorine level is below 170 ppm. The cure for excessive chlorine in the mains water supply would be a de-mineralisation plant or find a supply that does not have this contaminant. You can supply raw water to a resistance heater; but it will coat up with calcium with time and need cleaning.

Routine inspection and maintenance

Resistive heater cylinders are cleanable devices, made from either stainless steel or a heat resistant plastic with stainless steel elements. However calcium deposits will still be prevalent. The only way to reduce the sediment deposit is to address the feed water quality, or it will require inspection and cleaning during a service visit. The cylinder fitted in a resistive heater humidifier should not in the normal course of events, need to be changed. The procedure for cylinder removal will be in the manufacturers O & M manual but if elements are to be replaced, ensure the replacements are the same type and power, and that the integral cables are reconnected as the original.

Hygiene

Resistive element humidifiers, when boiling water to produce steam, will kill all known bacteria and introduce sterile moisture from the outlet point of the humidification system. This assumes all components within that system are applied in accordance to the guides and recommendations (published and freely available) from the manufacturer. When operational the temperature of all components in the steam path will exceed 60°C therefore sterilising those components as steam is passed through. At full output steam will be at 100°C, exceeding the limits set by ACOP L8.

4.1.3 Direct Steam Injection Humidifiers

Overview

Part of the Isothermal humidifier family and typically used when there is a ready supply of steam. Mainly used within the healthcare and industrial process applications where large capacities of steam are required. Normally humidification will only be a percentage of the total steam requirement of the associated boiler plant. Therefore for this document we have chosen to exclude the boiler and water supply from this section.

Principle of operation

Steam Injection Humidifiers will deliver dry steam for the humidification of air within AHU's and ductwork systems.

The system will typically comprise of a steam separator, steam lances, steam trap, control valve and actuator with associated pipe work and valves.

The steam flows through a filter (1) into a steam separator (3) where condensate is separated from the steam. The condensate is conducted into the ball float steam trap (6) where it will be discharged either back into the system or to drain. A start-up safety switch (5) measures the temperature of the condensate return. The actuator (12) is activated only when the start-up safety switch detects the optimal set temperature.

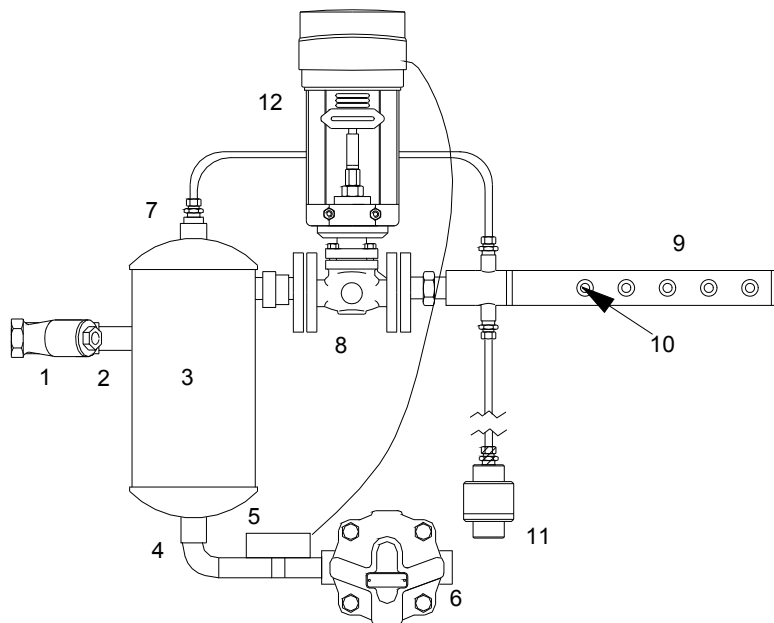

- 1 filter
- 2 steam inlet pipe union
- 3 separator
- 4 condensate outlet
- 5 electric startup safety switch
- 6 ball float steam trap
- 7 lance heating system connection
- 8 control valve
- 9 steam lance
- 10 nozzle
- 11 thermostatic capsule steam trap
- 12 actuator

The bulk of the steam will then exit the steam separator (3) and flows through the control valve (8). The control valve is automatically adjusted to the appropriate position via the aid of the actuator (12). Normally the steam lances (9) are either flanged or screwed onto the exit port of the control valve(8).

The steam is then forced through specially designed jacketed or pre-heated lances (9) into the airflow within the AHU or duct work.

The control of humidification operation is normally fully automatic with built-in safety interlocks and regulated by humidity sensor and integrated controller, humidistat or building management systems.

Water supply

We have not taken water supply into account with this system.

Hygiene

The production of steam will kill all known bacteria and introduce sterile moisture from the outlet point of the humidification system. This assumes that all components within that system are applied in accordance of all components to the guides and recommendations from the manufacturer. When operational the temperature of all components in the steam path will be in excess 105°C therefore sterilising those components as steam is passed through. At full output steam can be at up to 180°C @ 3 bar g, exceeding the limits set by ACoP L8 concerning Legionnaires' disease.

Routine inspection and maintenance

Inspection and maintenance of pressurised direct steam injection humidifiers should only be carried out by suitably trained persons, and in accordance with the manufacturer's maintenance procedures and technical service manual.

Before attempting any maintenance on this type of equipment, ensure that the assembly is fully isolated from the main steam supply. All electrical circuits must be isolated (fuses removed) or disconnected. Pneumatic controls (if fitted) must be completely isolated and/or disconnected. Ensure that the complete system is allowed to fully cool down.

For the system to operate without any problems, the following checks and maintenance tasks must be carried out on a regular basis.

Monthly:

- Check any flange bolts for tightness and adjust as appropriate.
- Check any gland seals for tightness and adjust as appropriate.
- Visually inspect all pipe work and joints for leaks.

Yearly

- Inspect the valve, checking for wear or scale deposits. Worn or damaged parts, like the plug or seat may need to be replaced as well as the gland seal packaging.
- Any graphite packaging is subject to wear. It is therefore recommended to replace such items.
- Check lances for wear or nozzle blockages.
- Check for absorption carry-over.
- Check valve and actuator.
- check the strainer and clean or replace the mesh.
- Check ant isolation valves for complete isolation and free movement.
- Test operation of separator and preheat seam traps.
- Check the function of the switch-off devices, e.g. the max hygrostat.
- Function test the system fully for correct operation.

Note: if the system has been out of operation for more than 3 months then the system should undertake a yearly maintenance and then be subject to a re-commission.

All monitoring and maintenance activity should be recorded in a log, particularly that relating to Legionella monitoring and control.

Summary

The routine maintenance of pressurised steam injection system is straightforward but they should be maintained only by suitably trained and competent individuals and in accordance with expert risk assessment and the manufacturer's instructions. They should be left switched on during normal operation and during periods when not in use to permit purge and flush cycles to continue so that stagnation is prevented. In the event that the system is turned off for a prolonged period, the equipment should be decommissioned and pipework suitably flushed during re-commissioning. If there is any doubt about the good operation or condition the humidifier it should be switched off and isolated, and expert advice sought before putting back into operation.

4.1.4 Gas Fired Humidifiers

Overview

Gas fired humidifiers, part of the isothermal humidifier family are typically used in large industrial applications such as the food industry, manufacturing, hospitals and demanding environments with 24 hour operation. This is typically achieved by injecting steam directly into an Air Handling Unit (AHU) or duct using steam distribution pipes. Occasionally the smaller output units are used for distribution directly into the area to be humidified.

Principle of operation

Gas humidifiers produce non-pressurised steam by means of a heat exchanger, this steam is distributed through steam lances into the AHU or ductwork. The humidifier consists of a tank with one or more heat exchangers immersed in water. A burner and fan assembly is linked to supply heating via combustion gases to the heat exchangers which in return boil the water in the tank producing sterile steam which is then injected into the desired environment that requires humidification.

The control panel on the gas humidifier regulates the fuel mixture in the gas burner and fan assembly. These systems also include many safety features such as temperature sensors in the exhaust flue which detect signs of malfunction, also included are double closing air and gas valves, a flame detector in the burner that closes the gas valve in the event of malfunction. The operation of these systems is fully automated and regulated via humidity sensors, integrated controller and also building management systems.

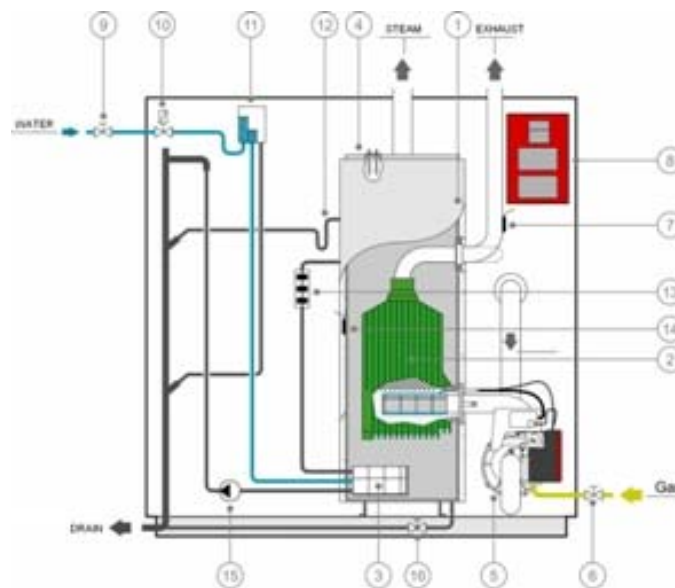

1. BOILER
2. HEAT EXCHANGER
3. FILTER
4. FOAM ELECTRODES (AFS)
5. BURNER
6. GAS TAP
7. FUMES PTC SENSOR
8. CONTROL PANEL
9. SUPPLY WATER TAP
10. FILL SOLENOID VALVE
11. (NOT PRESENT ANYMORE)
12. OVERFLOW
13. WATER LEVEL SENSORS
14. WATER NTC SENSOR
15. DRAIN PUMP
16. DISCHARGE TAP

Water supply

The water characteristics used tend to affect the evaporation cycle. Gas humidifiers are normally supplied with mains water, the general rule of thumb is to use water that is potable, demineralised or treated using a softener. The water lost in the evaporation cycle is automatically replaced using a fill valve on the water supply. The requirements of an application generally determine what type of water is the most suitable this is dependent on the end users requirements with regards to hours of operation, maintenance and demands of the site.

Fuel supply

The common fuels used to run the burner combustion are Natural gases (G20 or G25) Propane (G31) and Butane (G30). It is important to calibrate the burner and fan assembly for the correct fuel type as each fuel produces a different calorific value during combustion. The supply fuel/gas pressure should always be stated by the manufacturer (this varies from 20 mbar to a maximum of 60 mbar). Fuel Isolator valves are required to be installed in close proximity to the humidifier as stated in current gas regulations, these must always be adhered to.

Hygiene

Steam produced from the steam distribution pipe does not pose a hygiene threat when injected into the environment, but you should always refer to the manufacturers recommendations for all installation requirements and care should be taken to follow these at all times. Deviation from the recommended installation requirements may affect warranty of the equipment and pose a health and safety risk.

Gas humidifiers have an automatic drain down function during periods of inactivity. It is important that the humidifier is left on from the control panel to allow the desired drain cycles to be carried out. If a power down of the humidifier is required, it is important to drain the entire boiler to minimise risk of water stagnation.

Routine inspection and maintenance

Inspection and maintenance of gas fired humidifiers should only be carried out by suitably trained persons, and in accordance with the manufacturer's maintenance manual and according to governing regulations (e.g. gas standard compliance).

Before any work is carried out, make sure that the water in the boiler is drained completely. All facilities, gas, electricity and water need to be isolated.

During operation, the evaporation cycle leaves mineral deposits that settle on the heat exchanger and inside the boiler; this affects the operation of the humidifier and therefore requires scheduled maintenance. Factors such as the water quality and the duration of operation determine the frequency of the maintenance period. Using de-mineralised water generally results in a virtually maintenance free boiler and heat exchanger. Generally the humidifiers display a maintenance warning either as a result of operational hours or due to excessive scale build up in the boiler.

The hydraulic and mechanical maintenance inspections of the humidifier should consist of regular monthly inspections of the water drain pipes, steam pipes and general running of the humidifier is advised. The boiler is normally inspected every 3 to 6 months to check for signs of scale build up. To open the boiler, all steam hoses are disconnected and access to the boiler is achieved by opening the various access panels.

To maintain the heat exchanger and the burner head, an authorised and qualified person is required. This is generally carried out every six months. The heat exchanger is removed by disconnecting parts of the burner and fan assembly to release the burner combustion head. Once the heat exchanger is removed, it is cleaned using 20% acetic acid solution. The burner head is cleaned using a brush to remove any particulates such as tiny metal fragments resulting from previous combustions, the fan assembly is then disconnected and brushed to ensure that there is no dust in the system.

It is advisable to check and replace the gaskets when re-assembling all the gas burner component parts. The ionisation current is checked as per the manufacturers requirements to ensure correct operation during start up.

Once the unit is re-assembled, test the humidifier through at least two fill, operation and drain cycles and check for any water and gas leaks. Test all the operational features via the control panel such as the level float sensor, the exhaust temperature sensor and the general running of the humidifier. Inspect the steam distributors for any signs of damage or other anomalies. Correct where necessary.

It is also necessary to pay attention to adequate ventilation around the humidifier, and to ensure the flue is working in accordance with relevant regulations.

Finally reset all maintenance parameters and timers on the humidifier. All maintenance schedules should be logged for future references.

Summary

The maintenance of the gas fired humidifiers consists primarily of regular inspections of the pipe work, boiler and heat exchanger. The humidifiers should be maintained only by suitably trained and competent individuals when working on the water side; the gas side must be maintained by a registered gas operative. The work should be carried out in accordance with expert risk assessment and the manufacturer's instructions. During prolonged periods of inactivity, the boiler should be emptied to avoid stagnation of water.

4.2 Adiabatic humidifiers

Adiabatic humidifiers use cold water to humidify the air. There are two primary principles of operation, spray and wetted media (evaporative) humidifiers.

Spray systems typically produce a finely atomised spray which is introduced into the air flow within an air handling system or directly into the air in the environment to be humidified, such as a factory environment or a localised application such as a refrigerated display counter. Modern spray type humidifiers include high pressure atomisers, compressed air atomisers, rotary atomisers and ultrasonic humidifiers. Older spray coil and air washer systems produce a coarse spray inside air handling systems which passes through a cooling coil and/or droplet separator to remove larger droplets, leaving humidified air to pass along the duct.

In wetted media or evaporative humidifiers, air passes through a through a wetted matrix with a large surface area. Such matrices are commonly constructed of paper, glassfibre, ceramic or a combination of these. The matrix is typically installed within an air handling system although some self-contained systems stand in the environment to be humidified, such as in a factory.

In either case, the heat required to evaporate the water is drawn from the air itself, resulting in a drop in air temperature. This useful feature can reduce cooling costs although, at certain times of year, preheating of the air might be required to prevent the air temperature dropping below the desired level.

Because of the use of cold water, particular attention is required to ensure hygienic operation and the humidifier must be included in the risk assessment of a building's water system as a whole with respect to the control of Legionnaires' disease.

Many adiabatic systems run from a potable mains water supply but water treatment may be required according to the needs of the application or the operational requirements of the humidifier itself.

4.2.1 High Pressure Adiabatic Humidifiers

Overview

High pressure adiabatic systems can be employed within the ducted air stream of any cross sectional AHU or direct into a large room. High pressure nozzles produce a very fine mist which is quickly absorbed into the air.

Principle of operation

High pressure adiabatic humidifiers will normally consist of a high pressure (ca.70 bar) pump and a number of atomising nozzles deployed strategically.

Within AHUs, the nozzles are mounted on a framework across the duct and some use a wall of blocked fixed impellers designed to agitate or vortex the airflow. Distribution manifolds are used to connect the nozzles in series. The air and mist combine to produce an adiabatic state before it reaches one or more "droplet separators". These droplet separators eliminate larger water droplets before the humidified air reaches the main air distribution ductwork. Any excess water is drained away from the ductwork leaving no standing water.

In a direct room application the nozzles would be mounted on specially designed manifolds and/or fans. The high pressure mist is deployed at high level straight into the room.

In either situation, the control of humidification is achieved at a control panel which regulates the atomisation pressures (10-70 bar). This will also include failsafe bypass mechanisms to ensure water cannot pass out of the nozzles without sufficient pressure to achieve proper atomisation. Operation is fully automatic with built-in safety interlocks and regulated by humidity sensor and integrated controller, humidistat or building management systems.

Water supply

Due to the minute aperture of the high pressure nozzles only de-mineralised water having a conductivity of 5-20 μ S/cm should be used. The water temperature should be between 5-40°C.

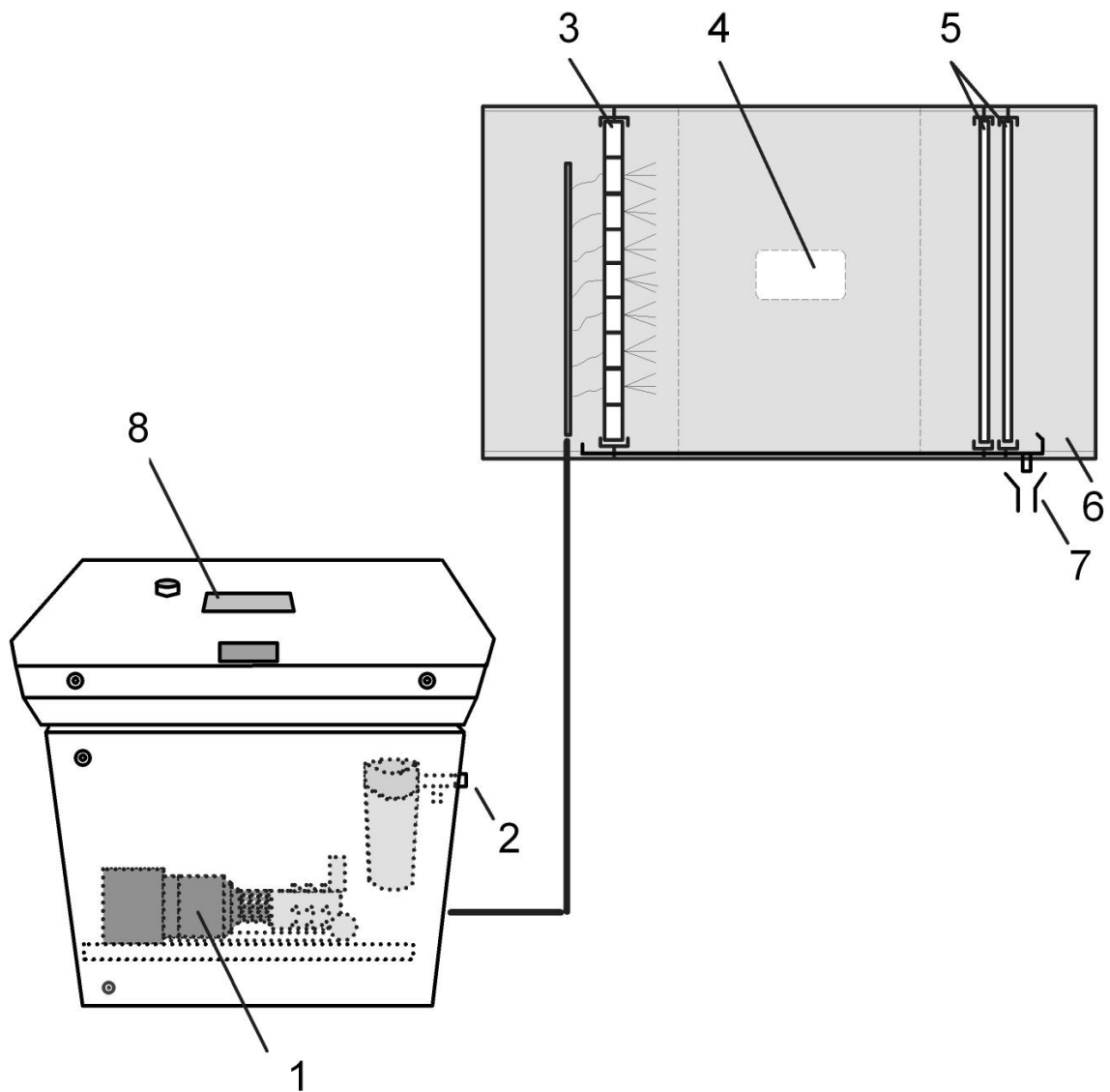

- 1: Pump group with mounted PLC cabinet
- 2: Water feed
- 3: Vortex module wall
- 4: Viewing window (necessary according to VDI 6022)
- 5: 2-stage droplet separator
- 6: Humidification chamber or duct with service doors and water tray
- 7: Water drain, siphoned
- 8: SPS-control

A water filter is commonly supplied for use immediately before the humidifier control panel to remove any sediment that might affect the operation of the components within.

Hygiene

The production of atomised sprays, particularly directly in the working environment, means that the water supply to the humidifier **must** be clean. It is essential that the water system in the building as whole is subject to monitoring for Legionella and that the high pressure humidifier is included in this regime. The Legionella risk assessment, monitoring and control must be undertaken by competent individuals, as per ACoP L8.

Only de-mineralised water is used in high pressure systems, therefore only de-mineralised mist is present in the ambient air. The system is automatically drained after a system shutdown. It is essential that the humidifier is left powered on during times where humidity is not required so that purge and flush systems can operate as intended. If powered off for a prolonged period, the humidifier should be decommissioned appropriately, including disinfection of all humidifier pipework, and similarly re-commissioned before putting back into operation.

Monitoring and control of Legionella

On commissioning and at regular intervals thereafter according to risk assessment, the humidification system should be tested for possible microbial water contamination using a proprietary test such as Dipslides. Water samples should be taken of the supply to the control panel and at the end of the nozzle line. Every six months, users are required by the ACoP L8 to take samples for Legionella analysis. In the event that Legionella is present or the microbial count is high, or evidence of biofilm is found, users are advised to switch off the humidifier and seek specialist advice on disinfection.

Routine inspection and maintenance

Inspection and maintenance of high pressure atomising humidifiers should only be carried out by suitably trained persons, and in accordance with the manufacturer's maintenance procedures and technical service manual.

Most high pressure systems are maintenance friendly. However, operational faults which can be traced back to inadequate or improper maintenance can occur. Regular maintenance to high pressure nozzle systems is indispensable for ensuring its long service life.

For the system to operate without any problems, the following checks and maintenance tasks must be carried out on a regular basis.

Monthly:

- Check water tray and housing for contamination and clean if necessary
- Carry out visual inspection of droplet separators and clean if necessary
- Check the high pressure pump oil levels
- Check the water filter cartridge upstream of the pump group for contamination and replace if necessary, flush the supply water system if necessary.

Yearly or (after 2500 hrs)

- Check the nozzles as part of the annual maintenance and clean in an ultrasonic bath if necessary
- Change the high pressure pump oil
- Replace the water filter cartridge
- Carry out visual inspection of the fixed impeller wall system and clean if necessary
- Check the function of the switch-off devices, e.g. the max hygostat

Note: if the system has been out of operation for more than 3 months then the system should undertake a yearly maintenance and then be subject to a re-commission.

All maintenance work and cycles are subject to ACoP L8

All monitoring and maintenance activity should be recorded in a log, particularly that relating to Legionella monitoring and control.

Summary

The routine maintenance of high pressure nozzle systems is straightforward but they should be maintained only by suitably trained and competent individuals and in accordance with expert risk assessment and the manufacturer's instructions. They should be left switched on during normal operation and during periods when not in use to permit purge and flush cycles to continue so that stagnation is prevented. In the event that the system is turned off for a prolonged period, the equipment should be decommissioned and pipework suitably disinfected during re-commissioning. If there is any doubt about the good operation or condition the humidifier it should be switched off and isolated, and expert advice sought before putting back into operation.

4.2.2 Compressed Air / Water Spray Humidifiers

Overview

Compressed air and water spray humidifiers are used to humidify large industrial environments, spraying directly in the air in situations such as textiles, tobacco, printing, chill stores, botanical gardens and automotive industries. These operate with on/off control, which is typically sufficient to meet the needs of such applications. Compressed air/water atomisers are also used inside air handling units to provide close control of humidity where humidity loads are high, using modulating control.

Principle of operation

Compressed air / water humidifiers consist of a number of atomising nozzles deployed throughout the area concerned on compressed air and water pipe runs. Within air handling systems, the nozzles are mounted on specifically-designed distribution manifolds. The compressed air and water combine at the nozzles to produce finely atomised sprays. These evaporate rapidly to raise the relative humidity in the area concerned or in the airstream in the air handling unit to the desired level.

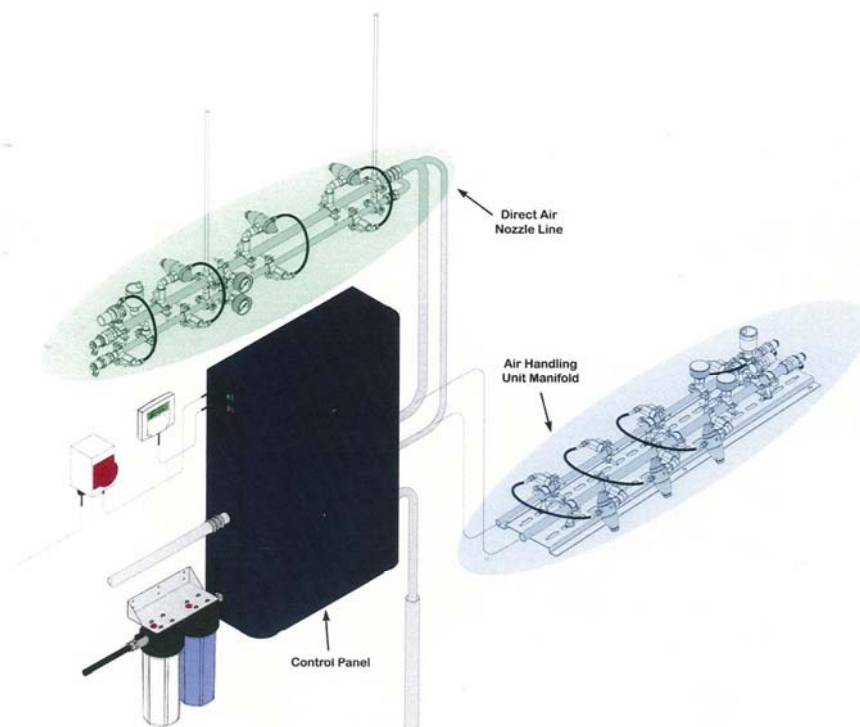

In either situation, the control of spray quality is achieved at a control panel which regulates compressed air and water flow and pressures. This will also include failsafe mechanisms to ensure water cannot pass out of the nozzles without sufficient compressed air to achieve proper atomisation. Operation is fully automatic and regulated by humidity sensor and integrated controller, humidistat or building management system.

Water supply

Potable mains water is the most common water supply and such nozzles typically incorporate self-cleaning features designed to avoid blockage by minerals contained in the water. However, depending on the water quality, and the requirements of the application, water treatment may be required such as reverse osmosis to remove minerals where residual mineral dust might be a problem.

A water filter is commonly supplied for use immediately before the humidifier control panel to remove any sediment that might affect the operation of the components within.

Compressed air supply

The compressed air supply should be clean, oil-free and dry. All compressors produce moisture but excessive moisture can disrupt the performance of the nozzles.

Most good quality air compressors incorporate an aftercooler to reduce air moisture content. An air receiver is recommended with automatic daily draining of any moisture and oil. Legislation in the UK requires that any condensate such as that from a receiver be as clean as possible, with separation of oil and water before entering the drainage system. Routine maintenance should be in keeping with the compressor manufacturer's recommendations and you should check what routine inspection is required to ensure compliance with local pressure directives and insurance requirements.

An air filter is typically positioned before the humidifier control panel to remove any residual condensate.

Hygiene

The production of atomised sprays, particularly directly in the working environment, means that the water supply to the humidifier **must** be clean. It is essential that the water system in the building as whole is subject to monitoring for Legionella and a programme of control, as per the guidance of ACoP L8, or similar local legislation, and that the compressed air/water atomising humidifier is included in this regime. The Legionella risk assessment, monitoring and control must be undertaken by competent individuals.

To minimise the risk of Legionella transmission, modern air/water atomisers typically include mechanism to avoid stagnation, such as cyclic purging of water supply pipework and flushing of nozzle supply pipework. These are often supported by antimicrobial water treatment such as silver ion or ultraviolet irradiation. It is essential that the humidifier is left powered on during times where humidity is not required so that purge and flush systems can operate as intended. If powered off for a prolonged period, the humidifier should be decommissioned appropriately, including disinfection of all humidifier pipework, and similarly recommissioned before putting back into operation.

Monitoring and control of Legionella

On commissioning and at regular intervals thereafter according to risk assessment, the humidification system should be tested for possible microbial water contamination using a proprietary test such as Dipslides. Water samples should be taken of the supply to the control panel and at the end of the nozzle line, and tested by an accredited laboratory. Every six months, users are required by the ACoP L8 to take samples for Legionella analysis. In the event that Legionella is present or the microbial count is high, or evidence of biofilm is found, users are advised to switch off the humidifier and seek specialist advice on disinfection.

Routine inspection and maintenance

Inspection and maintenance of compressed air/water atomising humidifiers should only be carried out by suitably trained persons, and in accordance with the manufacturer's maintenance manual.

Mechanical maintenance of air/water atomising humidifiers is typically straightforward, primarily comprising regular visual inspection of inlet and outlet compressed air and water supply pressures, visual inspection of the compressed air filter to check on air quality, and visual inspection of the sprays. This routine is typically monthly.

Airline components in the control panel, such as pressure regulators, pressure switches and solenoid valves, will require annual inspection and cleaning. According to compressed air quality, air filters immediately prior to the control panel will need cleaning or replacement between six months and a year.

Water line components in the control panel are subject to greater wear and tear, so six-monthly inspection of components is recommended, particularly in hard water areas, and sediment filter elements prior to the control panel should be changed.

Checks on the good operation and duration of the purge and flush systems should be made six-monthly, assuming that they have been set up correctly at commissioning. Where silver ion water treatment is used, elements require replacement between 6 and 24 months according to use. Weekly inspection of UV-lamp operation is recommended, although many compressed air systems using this technology incorporate failsafe systems to shut down the humidifier in the event of reduced effectiveness or failure. UV lamps should be changed annually or sooner according to use.

According to water quality and ambient conditions (such as a dusty manufacturing environment), the nozzles themselves may require periodic attention. As these might be situated high up in a factory environment or within an air handling system, suitable risk assessment and precautions should be taken.

All monitoring and maintenance activity should be recorded in a log, particularly that relating to Legionella monitoring and control.

Summary

The routine maintenance of air/water atomisers is straightforward but they should be maintained only by suitably trained and competent individuals and in accordance with expert risk assessment and the manufacturer's instructions. They should be left switched on during normal operation and during periods when not in use to permit purge and flush cycles to continue so that stagnation is prevented. In the event that the system is turned off for a prolonged period, the equipment should be decommissioned and pipework suitably disinfected during recommissioning. If there is any doubt about the good operation or condition the humidifier it should be switched off and isolated, and expert advice sought before putting back into operation.

4.2.3 Ultrasonic Humidifiers

Overview

Ultrasonic humidifiers are used in a variety of applications found in industrial, commercial and retail environments. They are commonly used in refrigerated display equipment to improve the shelf life and appearance of a variety of fresh produce. Fresh meat particularly benefits from additional humidity when retailed from a refrigerated counter.

Humidification, which relies on the fine atomisation of water, carries a risk of proliferating and spreading the potentially harmful bacteria, *Legionella pneumophila*. ACoP L8 Guidance should be used as a reference to reduce the risk of Legionella being dispersed into the atmosphere.

Following is a list of measures and precautions which should be considered when installing, maintaining and servicing this type of system.

Principle of Operation

Ultrasonic humidifiers produce atomised water using high frequency transducers mounted in the base of a water reservoir. The high frequency vibration cause cavitation of the water resulting in the atomisation of the water into a fine mist which can then be distributed, either to atmosphere, or ducted into equipment such as refrigerated counters or cold rooms.

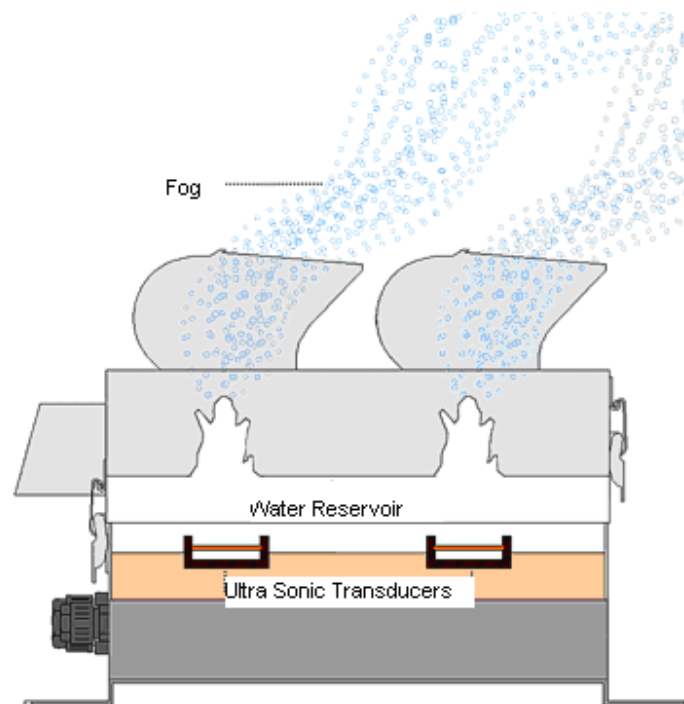

Water Supply

Ultrasonic humidifiers require a demineralised water supply, such as that provided via reverse osmosis. The use of pure water is essential for the efficiency of the unit and will also reduce maintenance and reduce risk of bacterial growth.

Any such treatment equipment should be installed by competent persons with suitable training.

Manufacturers' guidelines should be used to perform in the installation, commissioning and ongoing maintenance of any filtration or purifying equipment, but it may be necessary in certain applications to increase the service frequency, where water may carry the risk of higher contamination.

The servicing of water treatment systems is as important as regular servicing of the humidification equipment itself.

Humidifier

There are numerous designs of ultrasonic humidifier, however they all use the same mechanism for atomising the water, combined with an associated reservoir and various control elements.

Transducers, for example, will require changing at regular intervals; the manufacturer's instructions will give a guide to the service interval. Transducer life and efficiency can be affected by air quality and the purity of the water supplied. Poor quality water will result in deposits quickly building up on the surface of transducers and on other parts such as quartz sleeves, commonly used to encase UVC Lamps. As a consequence the efficiency of the equipment will be reduced and risk of bacteriological proliferation increased.

Some ultrasonic humidifiers incorporate safety features, to minimise the risk of microbial contaminants that may be in the fog before it is passed to atmosphere.

The most common is by way of germicidal UVC lamps strategically placed to irradiate the fog. UVC lamps in general have a life of approximately 8,000 hours, however due to the nature of their construction; the degradation in output accelerates towards the end of its useful life. Lamps should be changed at least annually and more frequently where they are run continuously, or subjected to frequent switching.

Any humidifier with integral UVC or other form of sterilisation should be fitted with an alarm system, audible, visual or both, which in the event of a failure, automatically shuts down the equipment and drains the water reservoir. This is essential to reduce the risk of bacterial proliferation in stagnant water, while the unit is idle.

Ozone generators are used in some units as an alternative or additional method of sterilisation. Manufacturer's guidelines should be followed when maintaining these units, which fall under additional legislation governing permitted exposure levels.

Water samples from any reservoirs and swabs from surfaces should be taken from the equipment at intervals, as determined by risk assessment. These should be tested for the presence of Legionella by a suitably accredited laboratory.

Associated Equipment

Where equipment is fitted in the vicinity of, or linked with anything likely to be a source of bacterial infection, an associated cleaning and sterilisation regime should be put in place. All such equipment must be installed in accordance with water regulations.

Record Keeping

Due to the inherent risk involved in operating and maintaining ultrasonic humidifiers, any business or individual involved in the maintenance of such equipment, should keep comprehensive records of maintenance schedules, service records and water sample analysis. In the event of litigation, as a result of a Legionella outbreak attributed to such equipment, such records will provide evidence of due diligence.

Records should be retained for a minimum of five years, in accordance with ACoP L8 Guidelines.

Summary

All ultrasonic humidification equipment should be maintained in accordance with manufacturers' instructions, with additional service actions necessitated by the various applications these systems are used for. If there is any doubt about the condition of such equipment it should be switched off and isolated immediately, and expert opinion sought, before re-commissioning.

4.2.4 Wetted Media (Evaporative) Humidifiers

Overview

Wetted media or evaporative humidifiers are typically used within air handling systems or often directly in the space concerned in industrial and agricultural storage operations. They are characterised by convoluted matrices through which air passes horizontally, with water trickling downward. Matrix material is typically paper- or glassfibre-based, often with a ceramic component. They may also include an antimicrobial element. Water evaporates from the surface of the matrix to raise the humidity to the level desired.

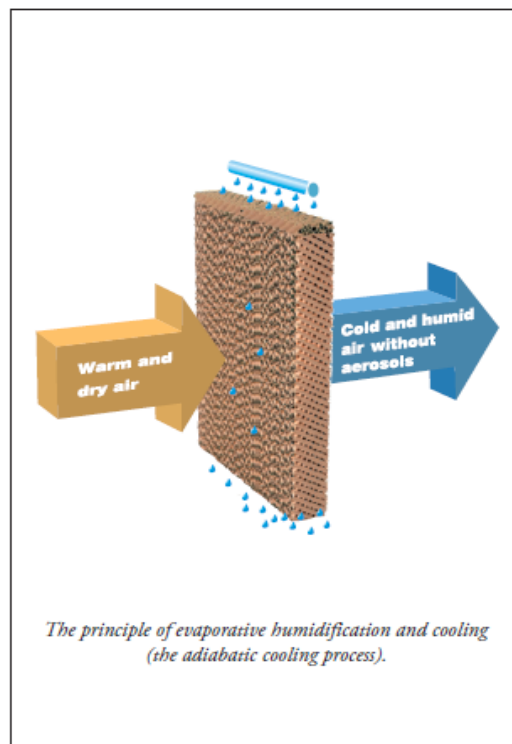

Principle of Operation

At the heart of an evaporative adiabatic wetted media humidifier is a matrix cassette. Water is supplied to the top of the cassette via a distribution header. The water flows down the corrugated surface of the media. As the warm and dry air passes through the media it evaporates a proportion of the water and thus produces cold, humidified air. The rest of the water assists in washing the media, and is drained back to the tank.

The energy that is needed for the evaporation is taken from the air itself. The air that leaves the humidifier is therefore humidified and cooled simultaneously without any external energy supply for the evaporation. This is in essence the adiabatic cooling process.

It also allows the use of water straight from the mains, in general, with no need for water treatment. Minerals and pollutants stay behind in the evaporative media to be washed away with the discharge water, keeping the total humidification process pure. Regular draining and flushing of the tank at the base of the humidifier reduces the risk of a build up of pollutants in the system, and supplementary systems such as UV water sterilisation and chemical dosing support this.

Water Supply

The units can generally be run on standard potable water. In very hard water areas, then a blend of RO and potable water can be used, to reduce calcification of the matrix and prolong its life. A chart of recommended water hardness can be obtained from your chosen manufacturer. Softened water is not recommended as it may produce a fine powder of sodium carbonate on the media cassettes, which could form a dust which is carried down the duct work when the humidifier is not in operation and the matrix dry.

Generic Routine Inspection and Maintenance

The frequency and extent of general maintenance varies according to manufacturer and you are reminded to read the suppliers' manual. However, typical maintenance involves:

- Replacement of inlet water filters
- Check inlet valve strainer and operation of all valves and pumps
- Check for hose condition and water leaks
- Check operation of all timers, alarms and ancillary equipment
- Clean the water distribution, brush off scale from the humidifier pad and clean the water sump.
- Change the UV bulb and quartz tube once per year
- According to the manufacturer's recommendations, at the end of the above checks and mechanical cleaning, the reservoir, hoses and matrices are chemically disinfected with 50ppm free chlorine for 1 hour. Neutralise the free chlorine before sending to drain and refilling with fresh water.

Consequences of not carrying out maintenance

The humidifier matrix cassettes should last between 4 and 8 years depending on water quality and run time. If maintenance is not carried out then there will be a gradual reduction in humidifier efficiency. At the worst case, the humidifier pads may block up or collapse so leaving the process without humidification, and an unforeseen bill. Some units on the UK market have run-time alarms to indicate when a service is due.

Frequency of Maintenance

It is recommended that the unit be thoroughly checked once every 6 months, with an interim check every month.

Hygiene

The design of wetted media humidifiers means that, correctly sized and installed, they will not produce droplets of water which could become entrained in the air flow. The evaporation of molecules of water ensures hygienic humidification of the air, whilst leaving behind minerals and possible bacteria to be washed down into the sump. This makes them a low risk with respect to building occupants with respect to Legionella.

Furthermore, systems are typically designed to ensure full draining of the sump and refill with clean water every 24 hours when the unit is in operation, and left dry when out of service. Side stream UV systems which circulate the sump water through a UV bulb, dosing systems or silver ion filters are also available to help maintain cleanliness.

However, to comply fully with the requirements of ACoP L8 due regard should be made to risk, such as the possibility of splashing of water in the sump during maintenance, and a preventative maintenance and inspection regime should be in place. See the manufacturers' maintenance manuals for guidance.

4.2.5 Spinning Disk Humidifiers

Overview

Spinning Disk or rotary adiabatic humidifiers are used in small to medium sized industrial applications. They are commonly used in cold rooms, stores, maturing rooms, small textile & printing industries. The humidifier is installed within the room where the very fine mist produced by the centrifugal spinning disk is quickly absorbed into the air thus providing humidification and adiabatic cooling. Spinning disk technology may occasionally be used in ducted applications, space permitting, but are ideally suited to cold stores due to the small sizes and adiabatic cooling effect. Some models are fitted with a frost protection device to operate down to -2°C.

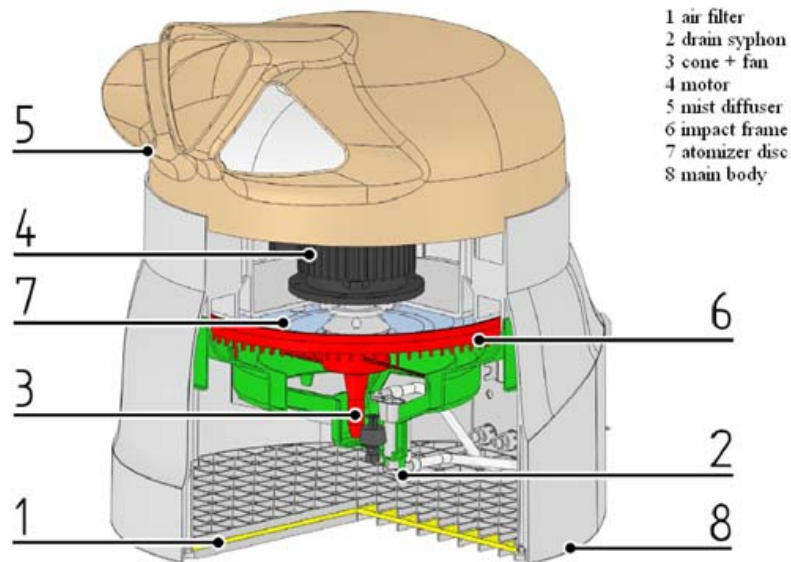

Principle of operation

Atomisation is performed by accelerating the water using a high speed spinning disk. The water is fed to a small sump at the centre of the unit where it is drawn up an intake cone due to the centrifugal effect of the rotating disk. From here it is accelerated and forced at high speed (>50m/sec) against the edge of the disk, fitted with teeth or blades. The impact of the water against these blades produces an aerosol with a very small droplet size.

After the water is atomised by the blades it is passed through a circumferential band that separates the coarser droplets, returning them to the collection sump. The aerosol produced is entrained and distributed in the room by the stream of air generated by the ventilating effect of the blades. Spinning disk units operate in on/off mode only.

Water supply

Potable mains water or demineralised RO water can be used with spinning disk technology. Remember that when using potable water, minerals present will be left in the area after evaporation. Water treatment such as RO may be required depending on the water quality, and the requirements of the application. A water filter is commonly supplied for use immediately before the humidifier to remove any sediment that might affect the operation of the components within.

Hygiene

The production of atomised sprays directly in the working environment, means that the water supply to the humidifier **must** be clean. It is essential that the water system in the building as whole is subject to monitoring for Legionella and that the spinning disk humidifier is included in this regime. The Legionella risk assessment, monitoring and control must be undertaken by competent individuals as per ACOP L8.

To minimise the risk of Legionella transmission, modern spinning disk atomisers use a very small collection sump thus having a high frequency of water change. A washing cycle is carried out at the start of each cycle and the sump is emptied at the end of each cycle. These are often supported by antimicrobial water treatments such as silver ion and/or ultraviolet irradiation.

If the unit is switched off for a prolonged period, the humidifier should be decommissioned appropriately, including disinfection of all humidifier pipe-work, and similarly re-commissioned before putting back into operation.

Monitoring and control of Legionella

On commissioning and at regular intervals thereafter according to risk assessment, the humidification system should be tested for possible microbial water contamination using a proprietary test such as Dipslides. Water samples should be taken of the supply to the unit and from the unit drain, and tested at an accredited laboratory. Every six months, users are required by the ACoP L8 to take samples for Legionella analysis. In the event that Legionella is present or the microbial count is high, or evidence of biofilm is found, users are advised to switch off the humidifier and seek specialist advice on disinfection.

Routine inspection and maintenance

Inspection and maintenance of spinning disk atomising humidifiers should be carried out by suitably trained persons, and in accordance with the manufacturer's maintenance procedures and technical service manual. Failure to maintain a spinning disk will result in the production of a heavy spray and a short service life.

For the system to operate optimally, the following checks and maintenance tasks should be followed

Weekly:

- Visual inspection of unit and spray
- Check UV lamp operation

Every 6 Months:

- Inspect & Clean the air filter
- Inspect & clean the drain siphon
- Inspect & Clean the fill solenoid
- Check the washing and emptying cycle
- Check the UV lamp operation
- Inspect & clean or replace the water sediment filter
- If Silver Ion sterilisation is used check and replace if necessary the elements
- Carry out sterilisation of the humidifier unit

Yearly:

- Same as 6 months plus: -
- Replace the UV lamp
- Check the float switch operation
- Check the motor turns freely

Note: if the system has been out of operation for more than 3 months then the system should undertake a yearly maintenance and then be subject to a re-commission.

All maintenance work and cycles should be subject to ACoP L8

Record Keeping

Due to the inherent risk involved in operating and maintaining Spinning Disk humidifiers, any business or individual involved in the maintenance of such equipment, should keep comprehensive records of maintenance schedules, service records and water sample analysis.

Summary

The routine maintenance of spinning disk systems is straightforward but they should be maintained only by suitably trained and competent individuals and in accordance with expert risk assessment and the manufacturer's instructions. They should be left switched on during normal operation and decommissioned when not in use for any prolonged period of time. The unit and pipe-work will require appropriate disinfection during re-commissioning. If there is any doubt about the good operation or condition the humidifier it should be switched off and isolated, and expert advice sought before putting back into operation.

4.3 Mobile and Portable Humidifiers

Overview

Mobile and portable humidifiers come in a wide variety of shapes and sizes, and work in a variety of ways including resistive and electrode steam, evaporative, rotary atomisers and ultrasonic. Mobile humidifiers are commonly larger than portable units and characterised by being supported on castors with removable water tanks that can be carried to the nearest tap for refilling. Portable units can be carried to the sink directly. Some units can be plumbed into a water supply permanently to avoid the need for refilling manually.

Portable humidifiers are widely used in the home and small office environments, and mobile units are commonly found in museums, art galleries, walk-in humidors and larger offices which otherwise lack humidification.

Principle of operation

These humidifiers operate on the same principles, but on a smaller scale, as the other humidifiers described in the previous sections. Refer to the relevant section for details.



Portable steam humidifier



Mobile evaporative humidifier

Routine inspection and maintenance

As these units are small and usually not plumbed into the mains water supply, it is easy to forget that they require routine maintenance to maintain their performance and to prevent the build-up of microbes. However, it is essential that the manufacturers recommended maintenance is carried out, particularly with respect to keeping the units clean, especially in units where an atomised spray is produced such as ultrasonic and rotary humidifiers. Portable and mobile humidifiers are usually situated at floor level and any spray produced can easily be inhaled by people living and working in the area being humidified. Left partially full of water but not operational over the summer months, the warm environment encourages the growth of microbes. In the commercial environment, you are advised to include them in the building's risk assessment for Legionellosis that is applied to the water system.

SECTION 5 – ANCILLARY SERVICES

5.1 Water supply and treatment

Introduction

All humidification systems need to be supplied with water. The specification of the water differs depending on the type of humidification technology employed. The hygienic quality of the water is always of paramount importance.

The diversity of types of humidifier and the range of services required means that many specifiers and contractors are unfamiliar with all aspects of their installation, commissioning, operation and maintenance requirements. It is therefore advisable to establish a good working relationship with the humidifier supplier at all stages of implementation from design and right throughout the working life of the humidifier concerned.

Maintaining the hygienic quality and the correct water specification during operation year after year is an essential requirement and responsibility of the user. The threat of scale formation and microbial contamination are of particular concern with all humidifiers, so regular maintenance to ensure their consistent and safe performance is essential. Failure to maintain them can result in reduced output, higher energy costs, shortened humidifier life, poor control of humidity levels and most importantly, health risk.

Water Supply

The water supply should be from a system which has been subjected to a risk analysis and sampling in accordance with current guidelines for the control and prevention of legionellosis, including ACoP L8. It should be of potable quality and should run at below 20°C within 2 minutes of turning on the supply.

Water should be taken straight off the incoming mains supply but where a tank is used, it must comply with the Water Regulations. Consideration should be given to avoid any supply that may become stagnant due to insufficient usage due, for example, to over sizing of the tank.

Water Treatment

Some humidifiers require water treatment for their good operation. However, even where this is not a requirement for the humidifier, consideration should be given to potential problems caused by water quality such as:

Calcium carbonate	which can increase the risk of the development of Legionella. Other problems include scaling of equipment and white spots on glass and other surfaces.
Suspended solids	problems include shadowing of microbes from UV light, build up of sediment, possible nutrient for bacteria.
Microbes	can cause slimes and biofilms and blockages as well as increasing the risk of Legionnaires' disease.

Methods of improving water quality for humidification systems include the following:

Pre-filtration (removes suspended solids and organics).

Pre-filtration is used to separate solids from fluids by introducing a medium through which only the fluid can pass. Oversize solids in the fluid are retained, but the separation is not complete as solids will be contaminated with some fluid and the product water will contain some fine particles (depending on the pore size and filter thickness).

A typical system may include a 10-micron sediment filter to trap particles including rust and calcium carbonate, a second sediment filter with smaller 5-micron pores and an activated carbon filter to trap organic chemicals and chlorine.

A pre filtration system is often used in line before a water softener or reverse osmosis system for added protection.

Water Softening (Ion Exchange)

A water softener reduces the dissolved calcium, magnesium, and to some degree manganese and ferrous iron ion concentration in hard water. A common water softening agent is sodium chloride which comes from the salt used in most water softeners.

Calcium and magnesium carbonates which form the hardness in water, tend to precipitate out as hard deposits or scale on various surfaces such as atomising nozzles, water or fog distribution pipes and heat exchangers. This is principally caused by thermal decomposition of bi-carbonate ions but also happens to some extent even in the absence of such ions. The resulting build-up of scale can restrict water flow in pipes and through nozzles. In boilers, the deposits act as an insulation that impairs the flow of heat into water, reducing the heating efficiency and allowing the metal boiler components to overheat. Ultimately, this can lead to failure of a boiler and the formation of rough surfaces on which bacteria or bio films can collect.

Where a high sodium level in the water is not desirable, such as in potable applications, hydrogen can be used in place of the sodium. However this type of softener cannot be regenerated on site and therefore where requires an exchange tank to be fitted which is a more costly process and generally not used where high volumes of softened water are required.

A water softener is often used in line before a Reverse Osmosis system in order to prolong the life of the membranes by preventing scaling of the membrane surface. This also allows the quantity of water passing to drain to be reduced significantly and results in more economical generation of product water

Reverse Osmosis (removes most dissolved solids and bacteria)

This process is best known for its use in desalination and is also used to purify fresh water for medical, industrial and domestic applications.

Reverse osmosis works by using pressure to force water through a semi permeable membrane, retaining the solute (concentrate, brine) on one side and allowing the pure solvent (product water) to pass to the other side. The membranes used for reverse osmosis have a dense barrier layer where most separation occurs. In most cases the membrane is designed to allow only water to pass through this dense layer while preventing the passage of solutes such as dissolved solids and bacteria.

Reverse osmosis removes 95-99% of most contaminants including microorganisms, organic compounds, dissolved inorganic compounds, microbial by-products such as endotoxins and pyrogens, and many carcinogenic compounds

The pore size in membranes used for purifying water are typically .001 of a micron in size. The size of a water molecule is .00032 of a micron, bacteria are typically 0.4 to 1 micron in size and a virus is about 0.2 to 0.4 of a micron, a human hair is about 100 microns.

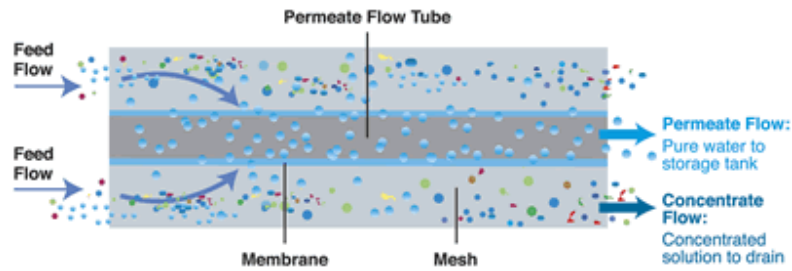

It must be acknowledged that any failure in seal between a membrane and its potential vessel, or damage to the membrane itself, will potentially allow the membrane to be bypassed and therefore a Reverse Osmosis system must not be considered as the only means of bacteria removal.

No minerals means no lime scale build-up in steam humidifiers, no dust carry-over in cold water atomisers and longer matrix life in evaporative units

Ultraviolet Disinfection

Reverse Osmosis processes are very effective barriers to pathogenic organisms, however ultraviolet (UV) disinfection is still used to kill any bacteria protozoa and virus that have bypassed the desalination process into the product water. For this application UVC is used as opposed to UVA or UVB. Whenever UV is used, prefiltration is necessary. Service personnel have to be aware of the dangers from UV radiation and observe the necessary precautions.

Service & Maintenance

End-Users must be made fully aware of the requirements for service and maintenance of water treatment systems associated with humidifiers and a suitably trained person be responsible for routine maintenance and water sampling.

The frequency and type of maintenance required will be specified by the manufacturer or installer of the water treatment system and must take into account the safe working duration of the systems components such as UV lamps, water filters, air filters, electrical components etc. This shall be reviewed by the end user of the equipment on the basis of a risk assessment of the situation and the system in use.

Persons responsible for maintenance of the water treatment system should record who the competent persons responsible for maintenance are, water sampling frequency, tests and results, routine maintenance, cleaning and disinfection dates and details, as per ACOP L8.

5.2 Humidity Controls & Calibration

For optimum safety and efficiency, routine maintenance of the humidity generation plant is essential, but however well this is carried out, final system performance depends greatly on accurate measurement and intelligent control.

5.2.1 Methods

There are various ways in which humidity control can be achieved:

Hygrostats (humidistats)

Consist of simple on/off switching around a set point, using either mechanical sensing (hair or membrane dimensional change) or electronic sensors (capacitive or resistive). In all cases, a relay switches at the user defined set point to activate the humidification equipment.

On/off control

An electronic sensor provides an electrical signal (mA or V) to a controller that converts this to an RH value. The user is able to define a set point where a relay switches the humidification on or off. Controllers can often be programmed with a hysteresis band to avoid relay 'chatter' when the measured value is very close to the set point value.

Proportional control (PID)

An electronic sensor provides an electrical signal to a PID controller that converts this to an RH value. Based on the user defined RH set point, the controller provides a variable output to control compatible humidification hardware with varying levels of output according to demand. For example, if the RH is close to the set point, lower output from the humidification system is required. Such proportional control avoids large variation in the controlled value, and may use less energy as a result.

Programmable Logic Control (PLC)

Usually working as a standalone module, a PLC incorporates multiple inputs for on/off or proportional control duty. It can also have supplementary functions such as digital inputs that allow for suspension of control when an event occurs. For example, the control can be programmed to hold when a door is open.

Building Managements Systems (BMS)

BMS systems are typically multiple channels and work on the basis of all the above methods depending on the application and plant requirement. BMS systems offer the advantage of a full system overview from a single PC workstation, and are often integrated together with building systems such as user access, security and energy monitoring. With this scope of integration and interaction, BMS systems offer the possibility of highly intelligent control and optimal energy use.

5.2.2 Installation & Commissioning Basics

Irrespective of the measurement technique or control strategy, correct implementation is essential. The following check points should be considered:

1. Is the measurement position clear of any sources of heat or humidity that can incorrectly modify the sensors measured value? Examples include light from windows, radiators, inlet air grilles, electronic plant and other sources of temperature.
2. If the sensor is mounted within a duct, is there sufficient distance from sources of heat or humidity for the measurement to be representative? Examples include humidification inlet, heater banks and fans.
3. At the point of installation, is the measurement sensors calibration known to be valid? Calibration certificates are only indicative of the condition at the time of test, so final commissioning checks should include verification and recording of humidity and temperature calibration.

5.2.3 Maintenance & Calibration

Within this guide there is insufficient scope for describing the maintenance requirements for every type of system. Most modern control equipment does not require routine maintenance to be able to perform correctly, but one should refer to operating manuals for guidance to identify what is required within ongoing system maintenance procedures.

However, one element of the system should always be included within maintenance procedures – calibration.

Humidity sensors of all types must be periodically checked to ensure that measured values are correct. Unlike other common measurement parameters such as temperature and pressure, humidity sensors suffer the disadvantage that they must be directly exposed to the environment to be measured, so any atmospheric chemical pollutants or dust will influence measured values. Maintaining instruments in a clean and dust free condition is a good first step, and should always include cleaning or replacing sensor protection filters where fitted.

Drift of humidity sensors is typically 1 to 5 %RH per year in ideal conditions; in 'dirty' environments 5 to 20%RH is not uncommon. Routine checks of calibration is the only way to solve this problem. Failure to maintain this will result in incorrectly controlled conditions and excess use of energy.

Single point calibration

A minimum requirement, and usually sufficient for steady state building control applications, a single point calibration check of the measured value should always be performed using a calibrated reference. This may be in the form of a handheld instrument or a humidity salt. Neither should be used unless a valid calibration certificate is available.



Temperature during any check must be very carefully considered as RH is so temperature dependent:

Relative Humidity	Temperature				
	10°C	20°C	30°C	50°C	70°C
10%rh	±0.7%rh	±0.6%rh	±0.6%rh	±0.5%rh	±0.5%rh
50%rh	±3.5%rh	±3.2%rh	±3.0%rh	±2.6%rh	±2.3%rh
90%rh	±6.3%rh	±5.7%rh	±5.4%rh	±4.6%rh	±4.1%rh

Effect of a temperature change of 1°C at various levels of temperature and relative humidity. The change in relative humidity values is not symmetric.

Source: A Guide to the Measurement of Humidity ISBN 0-904457-24-9

1°C temperature variance at 60%RH will resolve a 3%RH change, so if the calibration reference and the device under test are not at the same temperature, at least a 3%RH error will occur.

If using a handheld instrument, allow the instrument to stabilise in the room condition for at least 15 minutes before any test. Take note of the temperature stability throughout.

Multiple point calibration

In applications where the RH condition can vary, the measurement system should be calibrated at least at two points that 'bracket' the normal conditions (low and high). It may be impractical to change the control condition to achieve this, so it may be appropriate to remove the control instrument for calibration in a workshop or laboratory where temperature conditions are stable. Most manufacturers are able to provide a range of calibration options and services if the user does not have access to suitable methods.

SECTION 6 – CONCLUSION

6.1 Summary

Humidifiers are rarely installed solely for people's health and comfort. Whilst this might be desirable, there are usually sound commercial reasons for their use: improved productivity, supporting consistent manufacturing quality, the preservation of rare or valuable items, protection of critical data processing systems or to meet a particular regulatory requirement. However, despite usually being important parts of indoor environmental control systems with strong reasons for their inclusion, humidifiers are often the least understood and most neglected components.

This aim of this Humidity Group Code of Best Practice has been to help users benefit more fully from their humidifier investment by providing general guidance on what is required to commission and maintain the wide range of humidifiers in use today, and to help them operate their humidifiers hygienically and economically. Despite the detail contained in this Code of Best Practice and its worthy aims, however, it should be regarded as introductory and the manufacturer or supplier consulted for more specific information on the humidifier you have or intend to purchase.

In summary, whatever the type of humidifier, the conclusions regarding its upkeep are similar:

- it is essential to read the manufacturer or supplier's O&M manual;
- ensure that those carrying out the commissioning and planned maintenance are suitably trained and competent to do the work, particularly in relation to water hygiene. The supplier or manufacturer can usually provide maintenance support if required;
- the manufacturer's guidance should be adapted to meet the specific needs of the application itself and to accommodate supply water quality in a planned maintenance schedule. Plan ahead, don't resort to break/fix;
- keep a set of regularly used service items available on site;
- maintenance records should be kept for purposes of effective communication and traceability. In relation to water hygiene, this is obligatory;
- consult the manufacturer, supplier or a humidification specialist if advice, assistance or support is required. Any member of the Humidity Group will be pleased to help.

Suitably installed, commissioned and maintained, humidifiers can safely and effectively fulfil the reasons for their purchase for many years.

6.2 Further Information

Humidity Group website www.feta.co.uk/humidity/humidity-01.htm

Air Humidification, 2004, R. Lazzarin and L. Nalini

Thermal Comfort in the Workplace, 7/99 Health & Safety Executive

A Guide to the measurement of humidity, ISBN 0-904457-24-9

Environmental design, CIBSE Guide A



Published by the

HEVAC ASSOCIATION

THE FEDERATION OF ENVIRONMENTAL
TRADE ASSOCIATIONS
2 Waltham Court, Milley Lane
Hare Hatch, Reading, Berks RG10 9TH

Telephone No: 0118 940 3416

Fax No: 0118 940 6258

email: info@feta.co.uk

Website: www.feta.co.uk